

Parts List

Corrected to JUNE 1963

KODAK INSTAMATIC 100 CAMERA

and Field Case, Model A

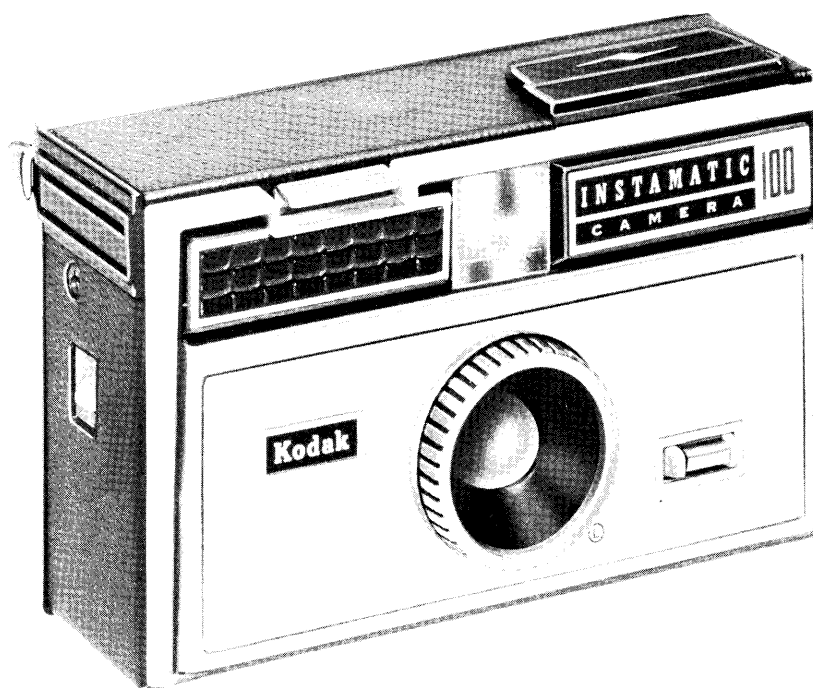

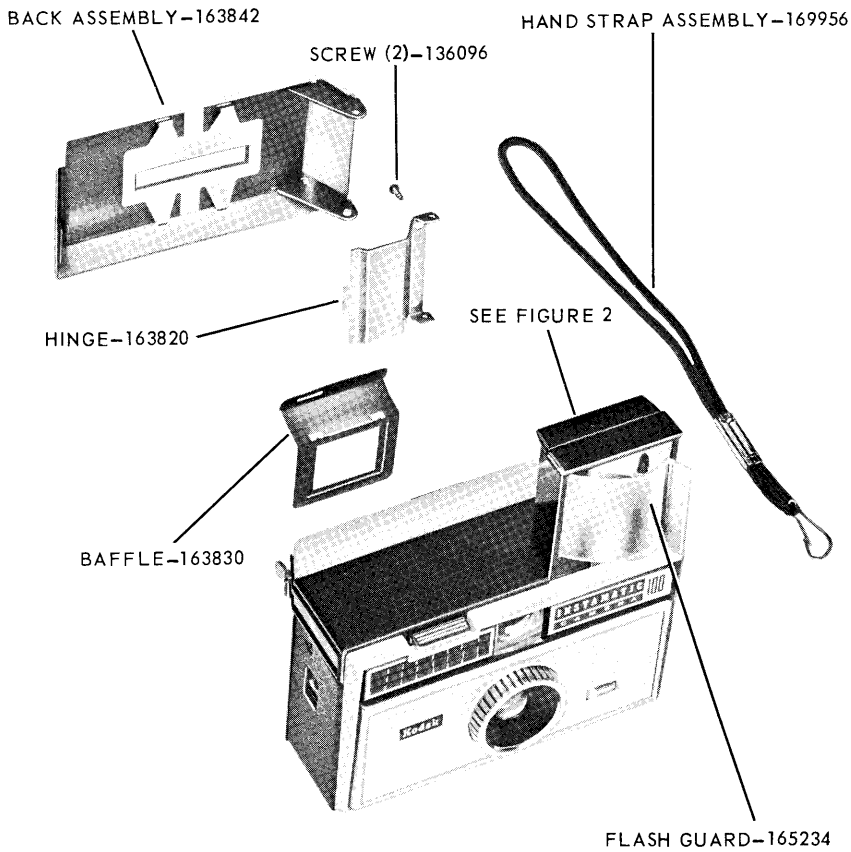

FIGURE 1

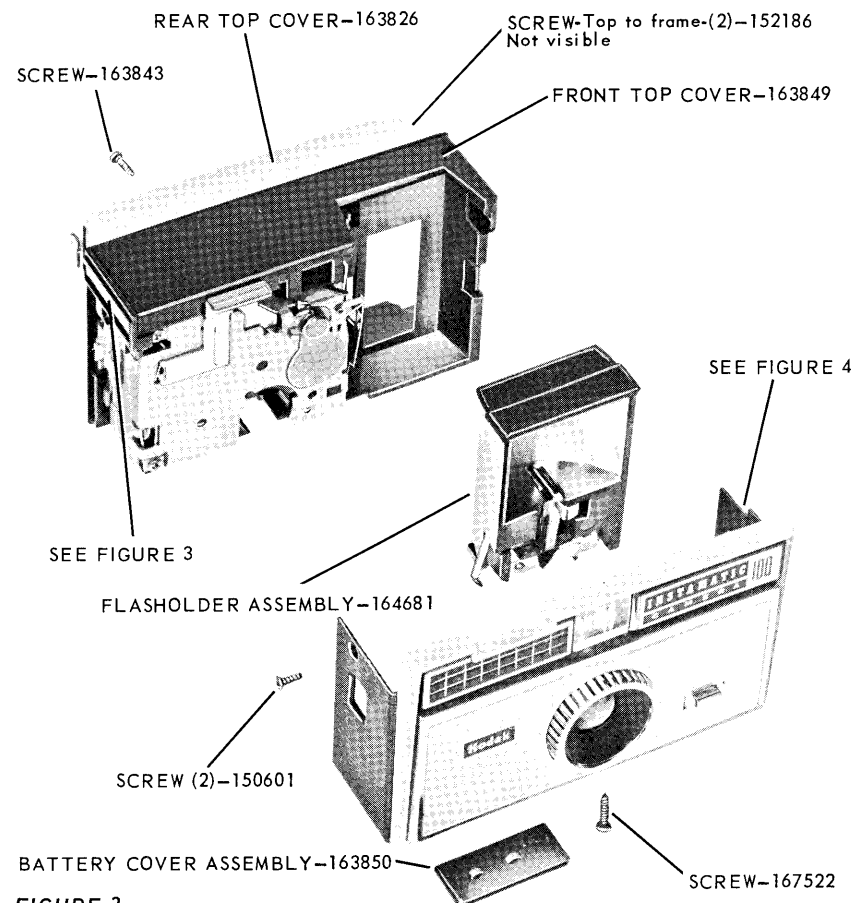

FIGURE 2

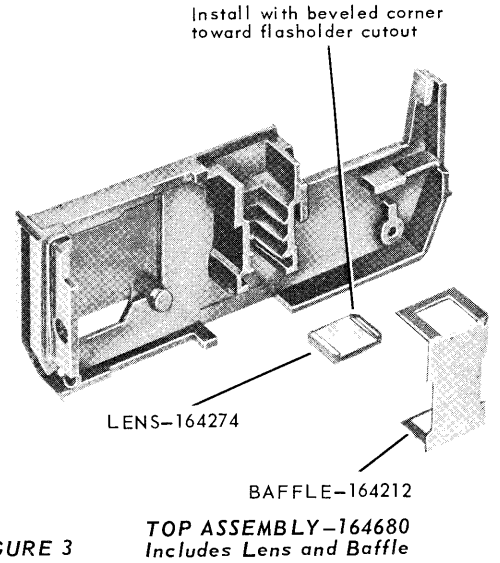

FIGURE 3

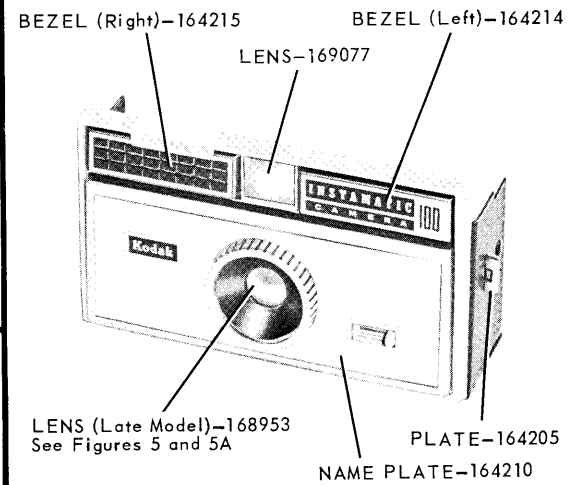

FIGURE 4 FRONT ASSEMBLY-166664

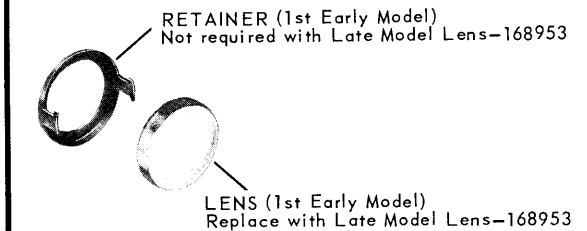

FIGURE 5 1st EARLY MODEL PARTS

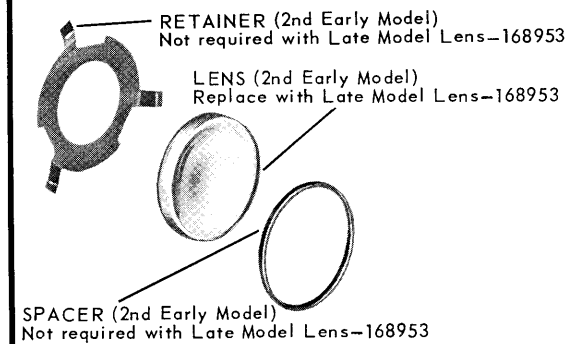

FIGURE 5A 2nd EARLY MODEL PARTS

Always give PART NUMBER and NAME when ordering parts

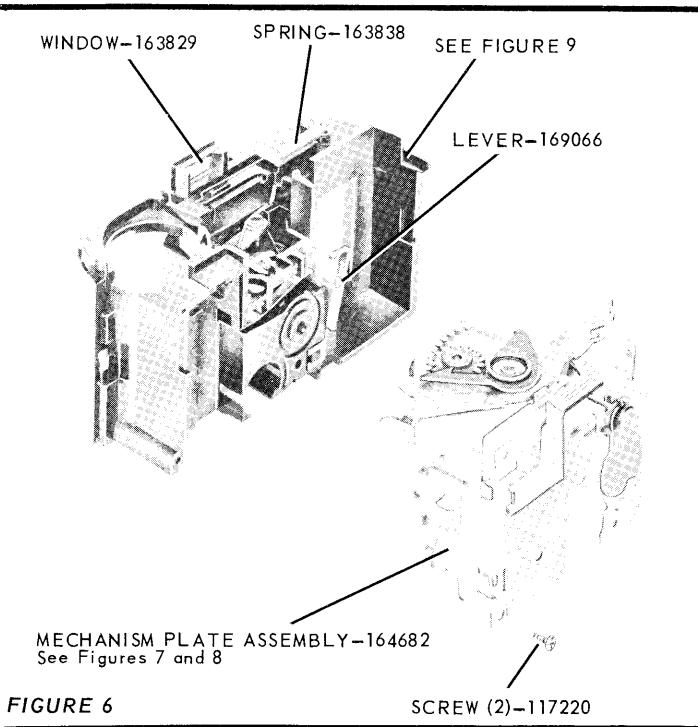

FIGURE 6

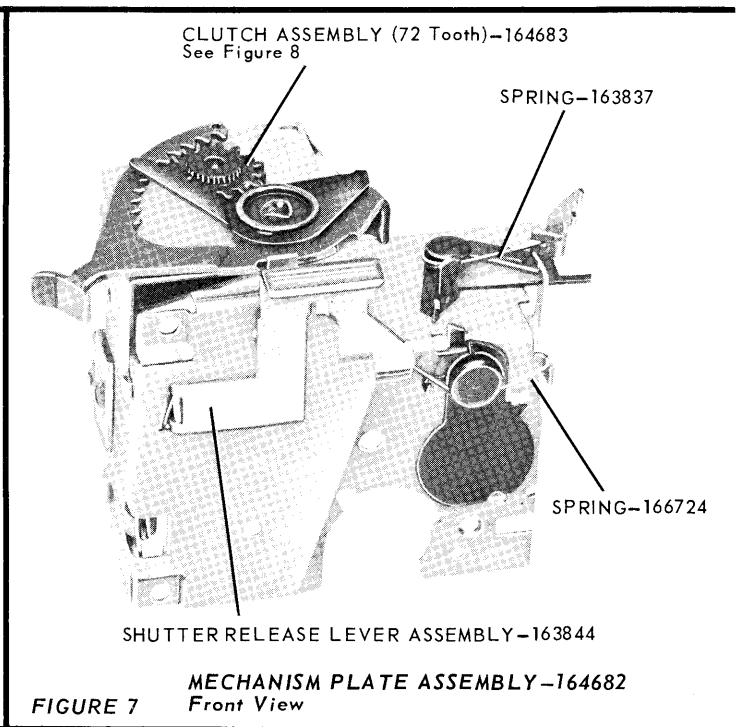

FIGURE 7

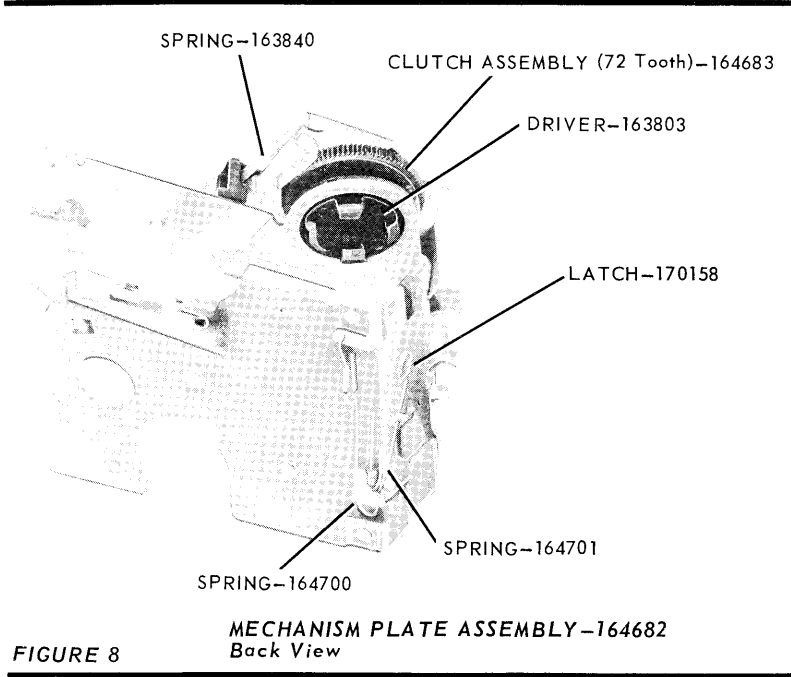

FIGURE 8

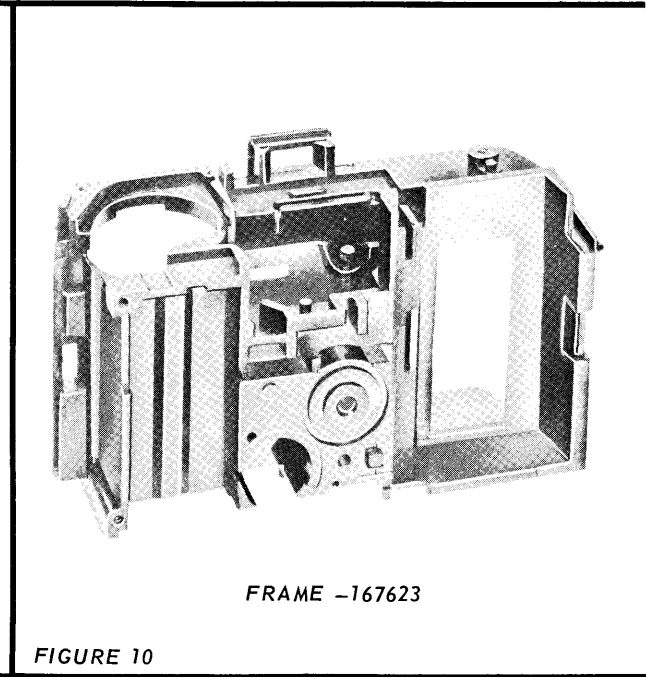

FIGURE 10

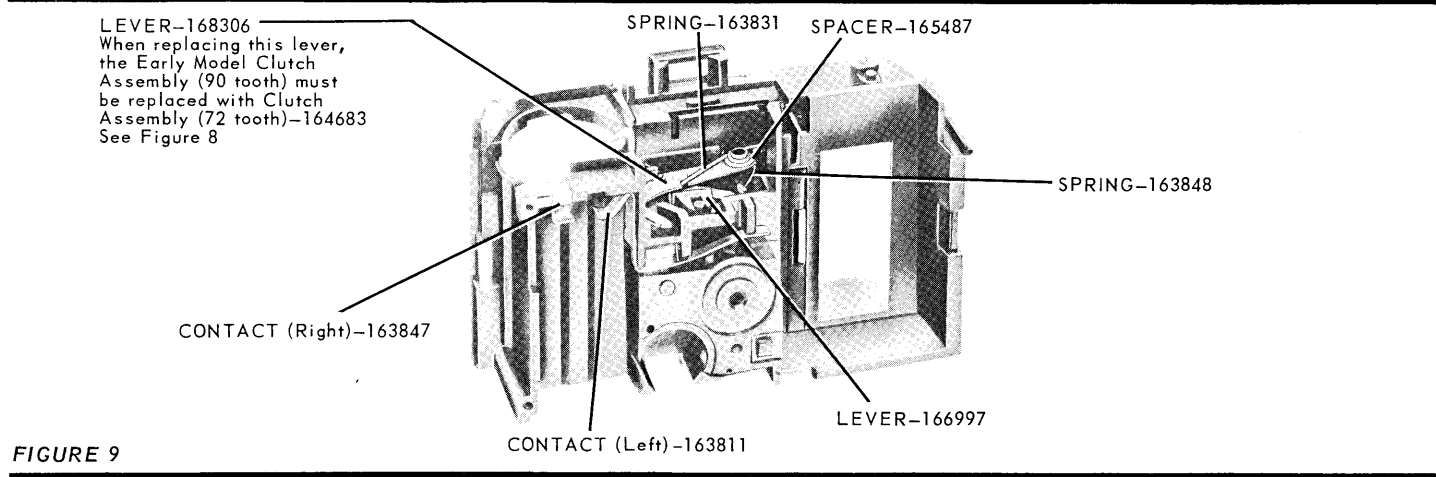

FIGURE 9

Always give PART NUMBER and NAME when ordering parts

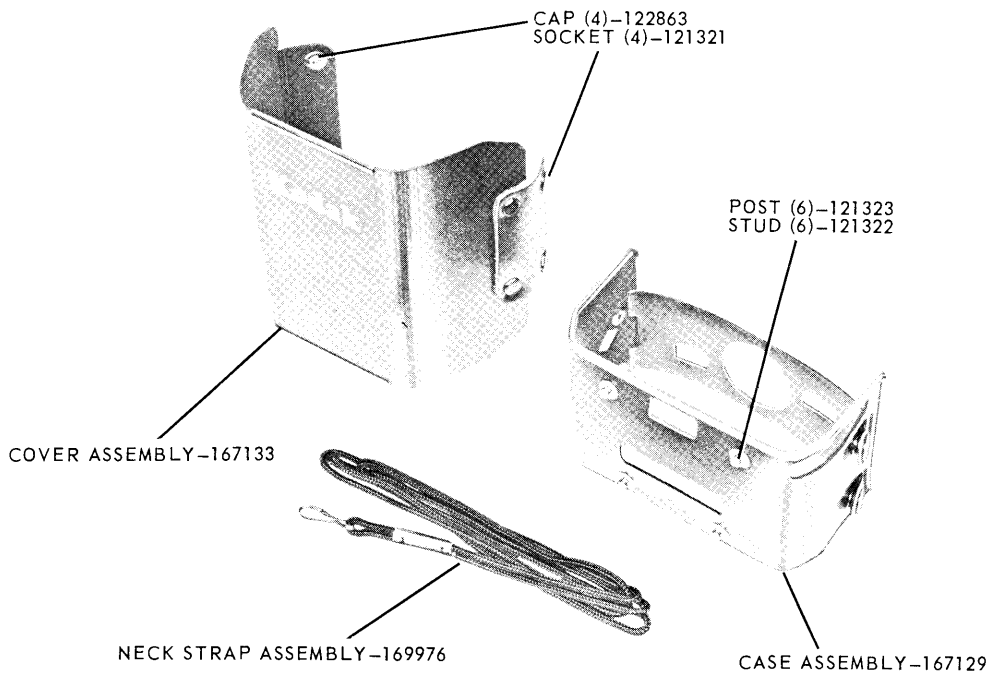

FIGURE 11 FIELD CASE, Model A

PART NO.	PART NAME	FIG.	PART NO.	PART NAME	FIG.
117220	Screw - Tap., Type B, pan hd, No. 2 x 3/16	6	164274	Lens - Finder, rear.	3
136096	Screw - Tap., Type B, pan hd, No. 2 x 1/4.	1	164680	Top Assembly.	3
150601	Screw - Tap., Type B, flat hd, No. 2 x 1/4.	2	164681	Flashholder Assembly.	2
152186	Screw - Tap., Type B, oval hd, No. 2 x 3/8	2	164682	Mechanism Plate Assembly.	6
163803	Driver - Spool	8	164683	Clutch Assembly.	7
163811	Contact - Battery, left	9	164700	Spring - Shutter release lever.	8
163820	Hinge - Back	1	164701	Spring - Latch	8
163826	Cover - Top, rear.	2	165234	Guard - Flash.	1
163829	Window	6	165487	Spacer - Metering lever.	9
163830	Baffle - Film sensing lever.	1	166664	Front Assembly	4
163831	Spring - Metering lever	9	166724	Spring - Shutter blade	7
163837	Spring - Shutter lever	7	166997	Lever - Film sensing.	9
163838	Spring - Winding lever.	6	167522	Screw - Front to frame	2
163840	Spring - Safety pawl.	8	167623	Frame.	10
163842	Back Assembly.	1	168306	Lever - Metering	9
163843	Screw - Tap., Type B, pan hd, No. 2 x 3/8.	2	168953	Lens (Late Model).	4
163844	Shutter Release Lever Assembly	7	169066	Lever - Shutter speed	6
163847	Contact - Battery, right	9	169077	Lens - Finder, front	4
163848	Spring - Film sensing lever	9	169956	Hand Strap Assembly.	1
163849	Cover - Top, front.	2	170158	Latch - Back	8
163850	Battery Cover Assembly	2	FIELD CASE, Model A		
164205	Plate - Hand strap.	4	121321	Socket.	11
164210	Name Plate	4	121322	Stud	11
164212	Baffle - Finder lens.	3	121323	Post	11
164214	Bezel - Finder, left.	4	122863	Cap.	11
164215	Bezel - Finder, right.	4	167129	Case Assembly.	11
			167133	Cover Assembly	11
			169976	Neck Strap Assembly.	11

EASTMAN KODAK COMPANY • ROCHESTER 4, NEW YORK

W.S.S. #374
(Supersedes #363)

JULY 1963

NO. 1359
(Supersedes #1345)

APPARATUS SERVICE REPAIR INSTRUCTIONS

KODAK INSTAMATIC 100 CAMERA

Repair at Divisions

Effective immediately, the Kodak Instamatic 100 Camera is to be repaired by the Apparatus Service Department (Rochester and Divisions) and by all Warranty Service Shops.

An initial supply of parts for this model is listed on the reverse side of this instruction and the quantity listed in the first column will be shipped to each Sales Division on Rochester S.O.'s. Please reorder in the usual manner and in accordance with practical estimates of usage.

A tentative service manual for the Kodak Instamatic 100 Camera is attached. The following new service tool is necessary to check the operation of Kodak Instamatic Cameras and two will be shipped to Canadian Kodak, each Sales Division, and each Warranty Service Shop:

#1065 - Kodapak Demonstration Cartridge.

This bulletin supersedes A.S.R.I. #1345 (W.S.S. #363).

EASTMAN KODAK COMPANY

F. H. WAKELEY, MANAGER

APPARATUS SERVICE DEPARTMENT

LIST OF PARTS
for
KODAK INSTAMATIC 100 CAMERA

<u>Quantity</u>	<u>Part No.</u>	<u>Name</u>
30	117220	Screw - Mechanism Plate
30	136096	Screw - Hinge
30	150601	Screw - Vinyl Wrapper
30	152186	Screw - Top
10	163803	Driver - Spool
10	163811	Contact - Battery Left
10	163820	Hinge - Back
40	163826	Cover - Top, Rear
30	163829	Window
20	163830	Baffle - Film Sensing Lever
10	163831	Spring - Metering Lever
10	163837	Spring - Shutter Lever
30	163838	Spring - Winding Lever
10	163840	Spring - Safety Pawl
10	163842	Back Assembly
30	163843	Screw - Front
10	163844	Shutter Release Lever Assembly
30	163847	Contact - Battery, Right
30	163848	Spring - Film Sensing Lever
10	163849	Cover - Top, Front
30	163850	Battery Cover Assembly
10	164205	Plate - Hand Strap
40	164210	Nameplate
10	164212	Baffle - Finder Lens
30	164214	Bezel - Finder, Left
30	164215	Bezel - Finder, Right
10	164274	Lens - Finder, Rear
10	164680	Top Assembly
20	164681	Flashholder Assembly
10	164682	Mechanism Plate Assembly
40	164683	Clutch Assembly
10	164700	Spring - Shutter Release Lever
10	164701	Spring - Latch
30	165234	Guard - Flash
20	165487	Spacer - Metering Lever
10	166664	Front Assembly
30	166724	Spring - Shutter Blade
20	166997	Lever - Film Setting
30	167522	Screw - Front to Frame
5	167623	Frame
30	168306	Lever - Metering
15	168953	Lens - Taking (Late Model)
20	169066	Lever - Shutter Speed
20	169077	Lens - Finder, Front
30	169956	Hand Strap Assembly
30	170158	Latch - Back

TENTATIVE SERVICE INSTRUCTIONS

for

KODAK INSTAMATIC 100 CAMERA

TABLE OF CONTENTS

	<u>Page</u>
1. SHUTTER	3
1.1 SPECIFICATIONS-----	3
1.2 SERVICE HINTS-----	3
1.3 REMOVAL OF FRONT FROM CAMERA-----	4
1.4 REMOVAL OF TOP FROM CAMERA-----	6
1.5 REMOVAL OF FLASHHOLDER-----	6
1.6 REMOVAL OF SHUTTER SPEED LEVER-----	6
1.7 REMOVAL OF SHUTTER BLADE SPRING-----	6
1.8 REMOVAL OF SHUTTER DRIVE LEVER SPRING---	6
2. FILM TRANSPORT	7
2.1 SPECIFICATIONS-----	7
2.2 SERVICE HINTS-----	7
2.3 REMOVAL OF MECHANISM PLATE FROM FRAME-	7
2.4 DISASSEMBLY OF MECHANISM PLATE-----	8
2.5 REMOVAL OF METERING AND SENSING LEVERS-	9
3. HOUSING	10
3.1 SPECIFICATIONS-----	10
3.2 SERVICE HINTS-----	10
3.3 REMOVAL OF BACK ASSEMBLY -----	11
3.4 REMOVAL OF VIEWFINDER WINDOW-----	11
3.5 REMOVAL OF BATTERY CONTACTS-----	11
3.6 DISASSEMBLY OF FRONT ASSEMBLY-----	11
3.7 DISASSEMBLY OF TOP ASSEMBLY-----	12
4. CEMENT AND LUBRICANT	13
4.1 CEMENT-----	13
4.2 LUBRICANT-----	13

SERVICE INSTRUCTIONS

KODAK INSTAMATIC 100 CAMERA

Service instructions for this camera are separated on a functional basis for clarity and ease of use by the serviceman. The instructions include specifications and service hints. The service hints sections have been written in a condition, cause, and remedy format for easy reference.

Service Tool #1065 - Kodak Demonstration Cartridge is useful in checking camera action during repair.

1. SHUTTER

1.1 SPECIFICATIONS

a) Shutter Speeds:

Daylight Speed, flashholder down	-	Total Time: 10 to 16 milliseconds
Flash Speed, flashholder up	-	Total Time: 19 to 28 milliseconds

- b) Flash synchronization may be checked with a flashbulb. When viewing from film plane, a full bright aperture opening must be observed when bulb is flashed. Shutter release should be pressed extremely slowly for this check. An alternate method of checking flash synchronization is by the following two observations. Flash contact should not be made while shutter release is held by Double Exposure Prevention device after cocking shutter but before film has been advanced fully. This checks for early flash. With front removed, observe that good contact is made between end of shutter release lever and left (long) battery contact before shutter is tripped. If good contact is not made at that time, flash will be late.
- c) After shutter has been set by movement of advance lever and DEP has been cleared by sensing lever, camera should flash an AG1 test lamp (part no. 761743) when shutter release lever is depressed. It should not be possible to flash a lamp when shutter release lever is held in DEP position.
- d) Shutter release lever should: operate smoothly without excessive force; trip shutter and return to UP position when released.
- e) Flashholder contact should connect lamp socket to flash circuit when flashholder is raised and disconnect lamp socket from flash circuit when depressed. Flash contact must be maintained while flashholder is in raised position even when flashholder is "rocked" slightly.

1.2 SERVICE HINTS

a) Shutter will not trip and film advance lever will not return.

Cause - shutter driver not "cocking".

Remedy - form end of film advance lever so that it will move shutter driver farther and to the "cocked" position.

b) Shutter held open.

Cause - shutter trapped by shutter speed lever.

Remedy - install new shutter speed lever or form upper arm of speed lever down toward bottom of camera so that shutter tang cannot pass arm of speed lever when flashholder is down. The shutter can be trapped accidentally by not raising flashholder fully. Camera should only be operated with flashholder all the way up or completely closed.

c) Shutter speeds slow.

Cause - excessive lubricant on shutter blade.

Remedy - clean shutter blade and surface of mechanism plate.

d) Shutter speed does not decrease when flashholder is raised.

Cause - shutter speed lever does not change in position.

Remedy - install new speed lever or form speed lever so that it has sufficient spring action to move away from shutter.

e) Failure to flash.

Before investigating camera, batteries and flash bulb contacts should be checked.

The flash circuit of Kodak Instamatic Cameras is unique. The drawing on the next page, pictorially and schematically shows this circuit.

Cause - loose battery cover.

Remedy - form bottom vinyl covering down to make battery contact fit tighter and/or install a new battery cover. The drawing shows the most effective position for forming the covering.

Cause - battery contact in camera deformed and battery rests too deeply in camera to make contact with battery cover.

Remedy - reach into battery compartment with a suitable tool and form battery contact toward battery cover. When batteries are positioned in battery compartment, they should be slightly above edge of mechanism plate and be depressed by battery cover when it is closed.

Cause - excessive lubrication on surface of frame which contacts back of flashholder. Small metal contact on back of flashholder picks-up this excessive lubrication and the lubrication prevents good flash contact.

Remedy - remove flashholder from frame and clean out lubrication on surface of frame which contacts back of flashholder.

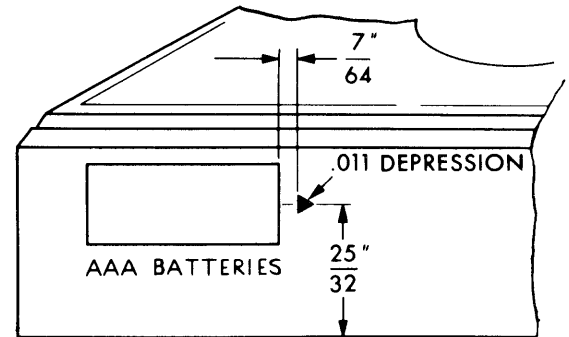

f) Flash possible even when shutter release lever is held by double exposure prevention device.

Cause - flash circuit not completed or an electrical short in shorting circuit.

Remedy - tighten upper mechanism plate screw so that there is good contact between right battery contact and mechanism plate.

Left battery contact should not touch silver part of shutter release. If it does touch at any time, there will be an incorrect electrical short.

Brass portion of shutter release lever should not touch mechanism plate. This also will create an improper electrical short.

1.3 REMOVAL OF FRONT FROM CAMERA

- a) Raise flashholder partially by depressing release bar.
- b) Remove two flat head screws from sides and one longer flat head screw from bottom.
- c) Open back of camera and remove sensing lever baffle. Baffle is most easily removed by placing a small tool into slot in baffle at sensing lever and then press downward and outward with tool to disengage top edge of baffle from frame. When replacing baffle, first, position lower edge of baffle to frame. Then, while holding in this position, allow top edge of baffle to come down into contact with frame, slot in baffle over sensing lever. Press baffle down into frame.
- d) Remove round head screw, immediately below aperture, from frame.
- e) Pry vinyl covered side panel out over back latch plate.
- f) Remove front from frame. Battery cover, which is trapped between vinyl bottom panel and frame will fall out. When replacing, position battery cover with printing at bottom of camera and visible thru hole in bottom panel. "Open" arrow should point toward center of camera.
- g) Before replacing front to frame, form tab on top vinyl panel out slightly so that it may be engaged in slot in front next to viewfinder lens.
- h) Position left end of front to frame with hand strap plate fitting into depression on frame. Rock front down and engage tab on top panel. Reposition battery cover if necessary and snap front to frame.

INSTAMATIC 100 CAMERA

SEQUENCE OF OPERATION

- Flashholder raised
- After an exposure and before film is advanced
 - Contacts ① and ② made
 - A and B open
 - A closes
 - B closes (current flows thru shorting loop)
 - A opens (current flows thru firing loop), bulb fires
- Shutter release lever starts down
- Shutter release lever continues down and shutter is tripped
- Shutter release lever rises

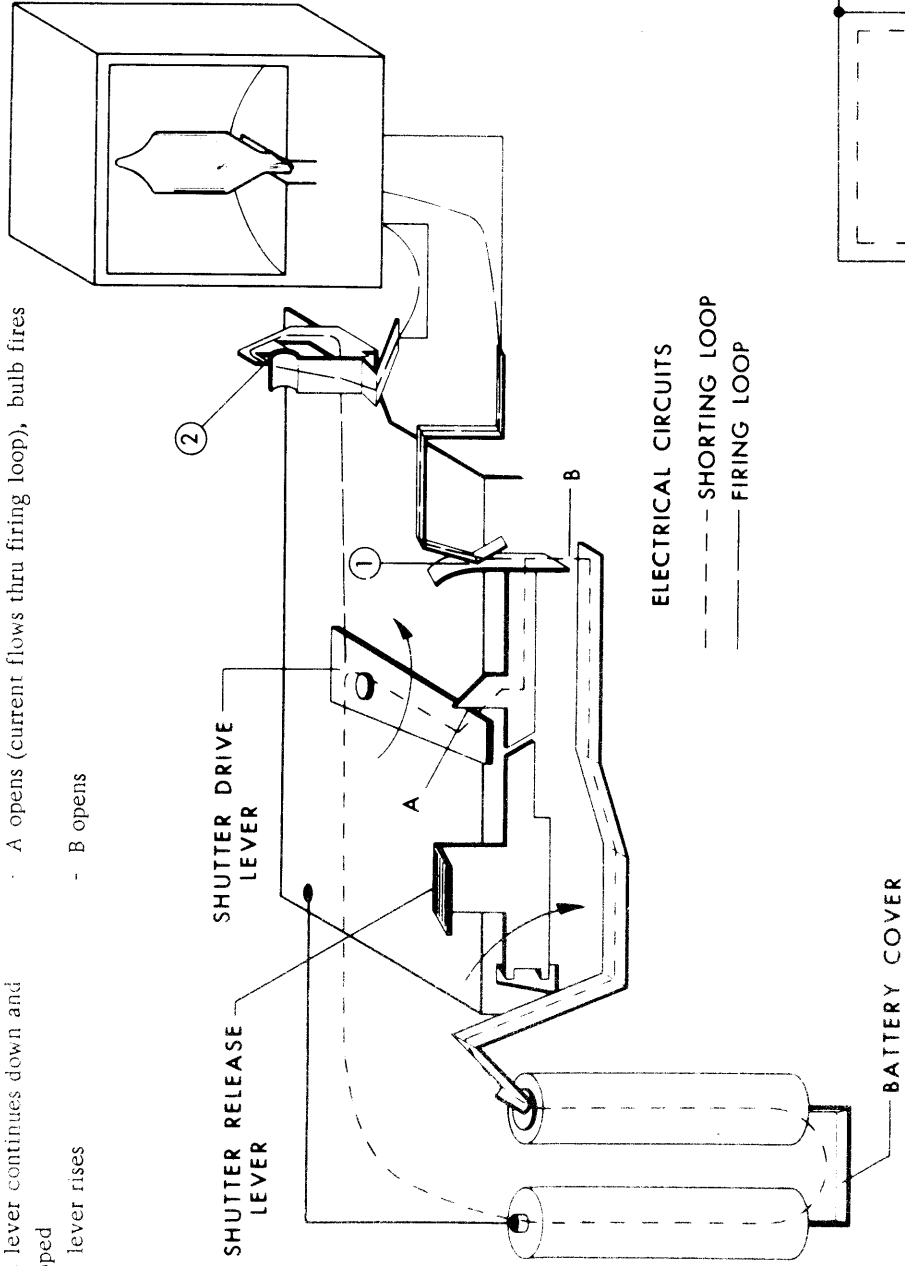

ELECTRICAL CIRCUITS
 - - - SHORTING LOOP
 — FIRING LOOP

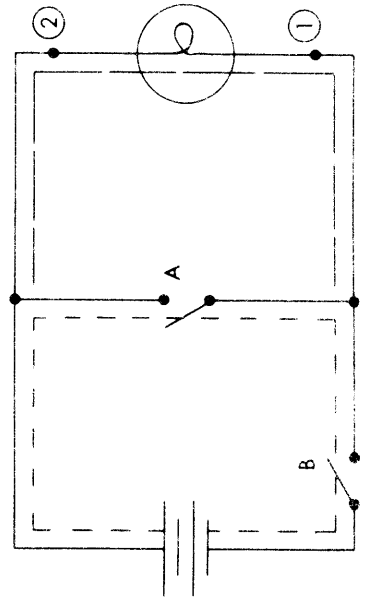

1.4 REMOVAL OF TOP FROM CAMERA

- a) Raise flashholder partially by depressing release bar.
- b) Pry up and remove metal rear top cover plate. It is cemented in position.
- c) Remove two screws holding top to frame.
- d) Remove flat head screw from side panel immediately above back latch.
- e) Film advance lever must be in the back (normal) position. Remove top from camera.
- f) Before replacing top, form tab on top vinyl panel out slightly so that it may be engaged in slot in front next to viewfinder lens. Also check to make sure clear plastic viewfinder window is still in position in frame.

1.5 REMOVAL OF FLASHHOLDER

- a) Remove front from camera, instruction 1.3.
- b) Raise flashholder fully. Twist flashholder to disengage side closest to outside of camera and lift flashholder from frame.
- c) Replace flashholder by compressing flashholder contact against end of shutter release lever and rock flashholder into frame. Hold shutter speed lever toward shutter stud. Press flashholder in against frame and slide down. Be careful not to distort shutter spring when sliding flashholder down.

1.6 REMOVAL OF SHUTTER SPEED LEVER

- a) Remove front from camera, instruction 1.3, and raise flashholder fully.
- b) Shutter speed lever is trapped in position by mechanism plate. "Barbs" on lever contact depressions in frame.
- c) When replacing speed lever, simply slip "barb" end of speed lever between mechanism plate and frame. Locating tab at upper end of speed lever should be carefully positioned on shutter side of raised tab, which holds shutter spring on mechanism plate.

1.7 REMOVAL OF SHUTTER BLADE SPRING

- a) Remove front from camera, instruction 1.3.
- b) Disengage shutter blade spring from tab on shutter and tab on mechanism plate. Lift spring from shutter stud.
- c) When reassembling, position shutter spring to shutter stud with short leg closest to mechanism plate. Engage short leg of spring in notch on top of shutter and long leg in notch on tab of mechanism plate. Shutter spring should not touch metering lever or shutter speed lever when correctly assembled.

1.8 REMOVAL OF SHUTTER DRIVE LEVER SPRING

- a) Remove top from camera, instruction 1.4.
- b) Disengage shutter drive lever spring from tab on mechanism plate and tab on shutter drive lever. Unwind loops of spring from stud.
- c) To install shutter drive lever spring, start with shortest leg down toward mechanism plate. Wind loops of spring onto stud. Engage short leg of spring with tab on shutter drive lever and wind up spring and engage long leg in notch on tab of mechanism plate.

2. FILM TRANSPORT

2.1 SPECIFICATIONS

- a) Film advance lever should operate smoothly and spring back fully when released.
- b) Film advance lever should cock shutter during first complete stroke of winding for each exposure.
- c) Film should advance as film advance lever is actuated and stop at each proper location for exposure (numbers on film backing paper, perforations on film in demonstration cartridge).
- d) Shutter release lever should be held by double exposure prevention device until film has been advanced fully to exposure location.

2.2 SERVICE HINTS

- a) Accidental jamming of film advance lever.

Cause - moving film sensing lever toward film advance lever either before or during actuation of film advance lever.

Remedy - press film sensing lever lightly toward front of camera, push film advance lever forward and allow it to return to rest position. Release film sensing lever and trip shutter.

This condition may also be rectified by simply placing a fresh film cartridge in camera and moving the film advance lever. The film backing paper in the cartridge will hold the film sensing lever in and allow actuation of film advance lever.

Cause - holding shutter release lever down, after shutter has been tripped, while moving film advance lever.

Remedy - if there is film in the camera, simply allow shutter release lever to rise and then actuate film advance lever.

If there is no film in camera, press film sensing lever lightly toward front of camera, push film advance lever forward and allow it to return to rest position. Release film sensing lever and trip shutter.

- b) Film transport system skipping exposures.

Cause - metering lever not engaging ratchet of clutch properly.

Remedy - examine operation of metering lever and condition of teeth on clutch ratchet. If metering lever action is bound, remove bind. If it is necessary to install a new metering lever, check the number of teeth on clutch ratchet. It must have 72 teeth, see instruction 2.5. If it does not, install a new clutch assembly. If teeth on clutch ratchet are not full or show wear, install a new clutch assembly.

- c) Film advance lever binds and fails to return.

Cause - burr on edge of film advance lever rubbing on top of mechanism plate.

Remedy - position a knife blade through slot in camera body and between lower side of film advance lever and top of mechanism plate. Move sharp edge of blade toward front of camera, with force, to remove burr.

- d) Film advance lever jams. (Other than accidental).

Cause - clutch assembly is defective.

Remedy - replace the clutch assembly.

Cause - shutter driver not "cocking".

Remedy - form end of film advance lever so that it will move shutter driver further and to the "cocked" position.

2.3 REMOVAL OF MECHANISM PLATE FROM FRAME

- a) Remove top from camera, instruction 1.4.
- b) Remove front and flashholder from camera, instruction 1.3 and 1.5.

- c) Actuate film advance lever one full stroke to cock shutter and allow lever to return to the rest position under spring tension. Do not "sense" mechanism by moving sensing lever. Metering and sensing levers are now in correct position so that mechanism plate can be removed without disturbing them.
- d) Remove winding lever spring by lifting spring loop from post on frame and disengaging opposite end from film advance lever.
- e) Disengage locating tab of shutter speed lever from contact with raised tab on mechanism plate.
- f) Remove two screws holding mechanism plate to frame.
- g) Pry up lower front edge of mechanism so that it snaps out off bosses on frame.
- h) Raise mechanism plate from frame. Care should be taken so that mechanism plate is not distorted. Platforms for shutter driver and winding mechanism must remain perpendicular to front surface of mechanism plate.
- i) When reassembling mechanism plate, first, correctly position sensing and metering levers by moving sensing lever to the left so that it holds metering lever as far forward as possible. Cock shutter drive lever and return film advance lever to normal rest position. Guide mechanism plate down onto frame with cut-out in mechanism plate going around tab on metering lever. Move metering lever tab slightly if necessary. Push mechanism plate down and snap over posts on frame. Late style frames have a boss on top surface near slot for safety pawl spring. If mechanism plate does not have a hole to accept boss, a hole must be drilled in mechanism plate. Be sure small right battery contact is located properly under mechanism plate. Attach mechanism plate to frame with two screws, film advance lever spring and check operation.

2.4 DISASSEMBLY OF MECHANISM PLATE

- a) Press in on tab of back latch and allow it to snap down into the "closed" position.
- b) Compress clutch drive spring fingers on underside of clutch assembly and slip black plastic spool driver from between clutch and back latch.
- c) Move film advance lever to forward position. Raise end of film advance lever and slip clutch assembly from mechanism plate. When replacing clutch assembly, flat washer in assembly fits into recess of ratchet wheel and mechanism plate slips between washer and upper gear.
- d) Remove shutter spring; short leg hooks on shutter and long leg contacts tab on mechanism plate.
- e) Disconnect shutter drive lever spring and wind it off stud. When replacing spring, position with short leg down toward mechanism plate, wind loops onto stud, engage short leg with tab on drive lever and long leg with tab on mechanism plate.
- f) Pull brass safety pawl spring from mechanism plate. Spring should have sufficient tension when assembled to move pawl into ratchet when pawl action is not restricted by shutter driver or film advance lever.
- g) Remove back latch spring. Snap back latch from mechanism plate by sliding back latch up and disengaging small tab of latch which contacts mechanism plate at front corner. If it is necessary to raise folded-over section of latch, a new latch must be installed. If original latch is re-folded, it will break. New latches will have the fold-over section perpendicular to remainder of latch. When installing a new latch, simply position latch and fold over section against mechanism plate with finger pressure, not with pliers. Section will spring back slightly to give proper clearance.
- h) Disengage shutter release lever spring from tab on mechanism plate. Rotate spring and disengage from shutter release lever.
- i) Remove shutter release lever from mechanism plate.

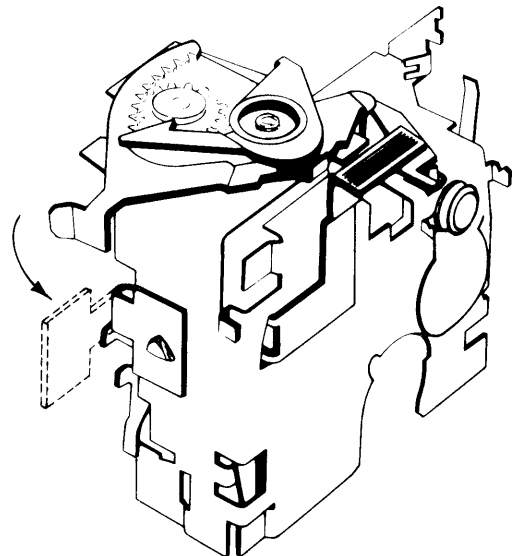

2.5 REMOVAL OF METERING AND SENSING LEVERS

- a) Remove front and top from camera, instructions 1.3 and 1.4.
- b) Remove mechanism plate, instruction 2.3.
- c) Disconnect and lift off metering lever spring. Short leg of spring fits into "well" in frame, long leg contacts metering lever.
- d) Lift off brass spacer and metering lever. If a new metering lever is installed, it is necessary to check clutch assembly in mechanism plate. Clutch assembly must have a lower ratchet with 72 teeth. Original clutch in many cameras have a ratchet with 90 teeth. These clutches must be removed and a new clutch (72 tooth ratchet) installed when a new metering lever is installed.
- e) Disconnect and lift out sensing lever spring. Short formed end of spring fits into hole in frame and long end contacts sensing lever.

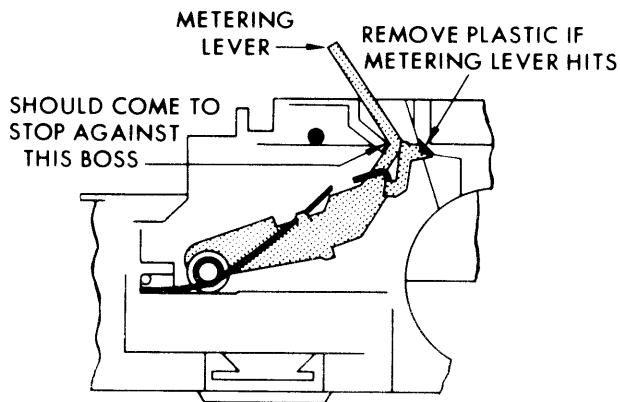
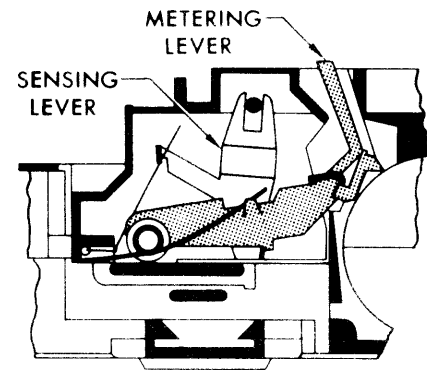

- f) Lift "yoke" end of sensing lever from post on frame, disengage opposite end from slot in frame and lift out sensing lever.
- g) Lubricate sensing lever and metering lever, at contact points between levers and between levers and frame, with a very light grease such as A&O #61-3663 when reassembling.
- h) When reassembling, check action of metering lever. Lower arm of lever should come to a stop against boss on frame. Pawl end of lever should not touch black plastic frame, see drawing.

3. HOUSING

3.1 SPECIFICATIONS

- a) Flashholder must pop-up at least slightly when release bar on front of camera is pressed.
- b) Raising flashholder to flash position should be possible without undue force after flashholder has been unlatched by release bar.
- c) Flashholder lamp socket should accept an AG1 flash bulb or test lamp without excessive force and retain it, if lamp has been inserted fully into flashholder.
- d) Lamp should be released when ejector lever is moved to its maximum travel. Lever should spring back when released.
- e) Back should fit case without severe interference.
- f) Back latch should snap down and hold back when it is closed.
- g) When a film cartridge in camera, back should pop-open slightly when back latch is moved up toward top of camera.
- h) Flashholder should latch securely when pressed down into camera.
- i) Taking lens should be securely held in position in front assembly.
- j) Battery cover should slide without severe interference but should be held securely in "closed" position by detent action. It should not be possible to even partially open battery cover accidentally by lightly moving finger over battery cover.

3.2 SERVICE HINTS

- a) Nameplate loose.

Cause - nameplate cemented to flashholder, release bar and actuation of bar loosens nameplate.

Remedy - remove satin finished nameplate (this plate has word "KODAK") from camera. The satin plate is cemented into recess of shiny plate. Cement may be softened by placing a few drops of solvent such as methyl ethyl ketone just inside recess of shiny plate. Pry up satin plate by starting at upper left corner (picture taking position).

Form flat part of release bar latch up away from front and remove cement from its surface. Form bar end of latch so that it will enter front perpendicularly. Raise flashholder. Press down upper most section of latch so that flat section fits down into well of front and lubricate the surface of this section. The lowering and lubricating of the flat area of latch prevents new nameplate from sticking to it. Cement new nameplate in position.

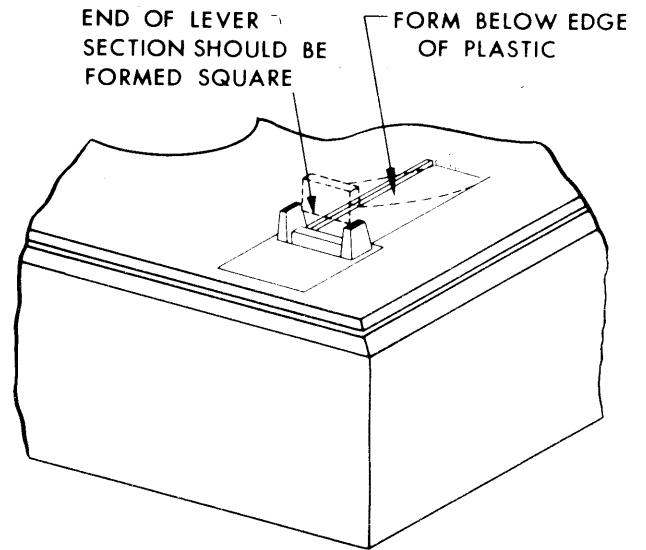

- b) Flashholder will not "pop-up" at least 1/4 inch.

Cause - bind between front and flashholder or flashholder and frame.

Remedy - perform the following steps in order and actuate flashholder after each step and observe action.

Grasp plate to which hand strap is attached with a pliers and pull outward.

Loosen side screw near hand strap plate, hold flashholder forward toward front with force, and tighten side screw again.

Position a knife blade immediately below flashholder release bar and form end of tang of release bar up toward top of camera.

With knife blade in same position, press in to compress tension of spring on front of flashholder.

Trim front edges of flashholder to remove sharp edge and any burrs. If flashholder is disassembled from camera, trim front edges for entire length of flashholder.

3.3 REMOVAL OF BACK ASSEMBLY

- a) Open camera back.
- b) Remove two screws holding back hinge plate to frame and lift back and hinge from frame.
- c) Spread hinge arms of back assembly and snap out hinge plate.

3.4 REMOVAL OF VIEWFINDER WINDOW

- a) Remove top from camera, instruction 1.4.
- b) Lift viewfinder window from frame.

3.5 REMOVAL OF BATTERY CONTACTS

- a) Remove front and top from camera, instructions 1.3 and 1.4.
- b) Remove mechanism plate, instruction 2.3.
- c) Snap small right battery contact from frame. When reassembled, hole in contact must be located over hole in frame.
- d) Remove longer left battery contact by squeezing "barbed" sides together and pull from frame. When reassembled, left end of contact, which is closest to flashholder, must be parallel to edge of frame just above it.

3.6 DISASSEMBLY OF FRONT ASSEMBLY

- a) Remove satin finished nameplate (this plate has word "KODAK") from front. The satin plate is cemented into recess of shiny plate. Do not try to remove shiny plate, it is crimped to front assembly. Pry up satin plate with a knife blade by starting at upper left corner (picture taking position). Cement behind plate may be softened by placing a few drops of a solvent such as methyl ethyl ketone just inside recess of shiny plate. This is the solvent which will best "activate" the cement on a new nameplate. Chlorothene is an acceptable substitute solvent. In most cases, a new nameplate will be needed for replacement.
- b) Remove black bezels from front. These bezels are also cemented in position. They are best removed by prying up at sides nearest viewfinder lens. These bezels have a cement backing but rather than activating this cement it is better to use a good rubber base cement such as A&O #10-1168 (Minnesota Mining and Manufacturing EC-1357).
- c) Lift out front viewfinder lens. When replaced, frosted section should go down toward taking lens. The supporting edges of viewfinder vary, some have short edge on right and others have it on the left, either is acceptable.
- d) In order to remove taking lens or hand strap plate, front must be removed from camera, instruction 1.3.
- e) With front removed from camera and nameplate removed from front, instruction 3.6 a, lift out hand strap plate.

f) If it is necessary to install a new taking lens, particular attention should be taken to observe lenses originally assembled to camera. Three different combinations have been used. If a new taking lens is installed, only assemble the new lens. All other parts should be removed and discarded. This includes retainer and lens (plano glass) in frame, and retainer and spacer in front. Retainer and lens in frame are most easily removed by applying heat (soldering iron) to retainer and pushing lens from front side. Position new lens directly to front and cement in place with a good styrene cement (same as that used in children's plastic model kits) or use HE 100 B which is available from Apparatus Parts Service. Be sure no cement or plastic burrs rise higher than edge of lens mount inside. These could interfere with shutter action.

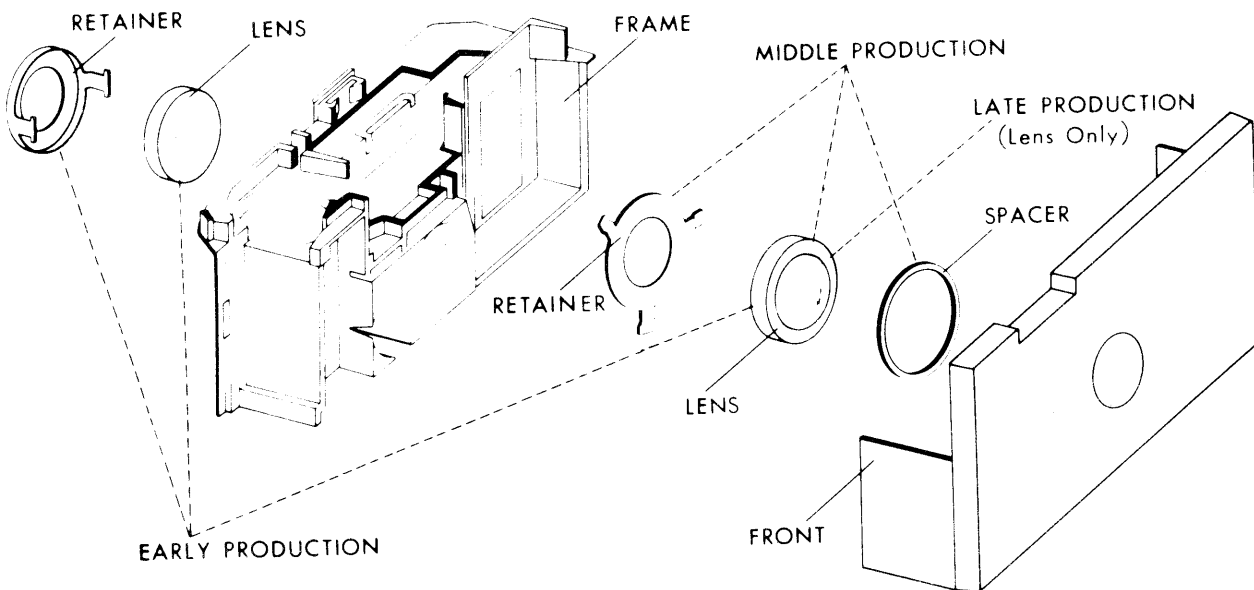

3.7 DISASSEMBLY OF TOP ASSEMBLY

- a) Remove black vinyl covering. It is cemented in position.
- b) Snap viewfinder baffle from top. Rear section of baffle slips into slot in top when reassembling.
- c) Pull viewfinder rear lens from top housing. It should be reassembled with beveled corner toward top of camera and nearest flashholder opening.

4. CEMENT AND LUBRICANT

4.1 CEMENT - A&O #10-1168 or Minnesota Mining and Manufacturing (3M) #001957 (Thinner-Toluol or Solvesso)

Left and right finder bezels to front assembly.

Black front top covering to top assembly.

Rear top cover plate to top assembly.

Front nameplate may also be attached with this cement or cement backing on plate may be activated with methyl ethyl ketone or chlorothene.

4.2 LUBRICANT - A&O #61-3663 or Dow Corning #33 Grease

Brush this lubricant at points of contact between the following parts:

Flashholder box and flashholder detent spring with front assembly.

Flashholder box and main camera frame but not any place which flash contacts touch.

Film advance lever teeth and clutch ratchet.

Film advance lever and top of mechanism plate.

Slot in mechanism plate which accepts clutch.

Mechanism plate and pivot point of shutter release lever.

Back latch and mechanism plate.

Pawl on metering lever which enters ratchet of clutch.

Metering lever tab and shutter release lever.

Metering lever tab and sensing lever tab.

FEBRUARY 1964

W. S. S. #384
(Addition)

NO. 1370
(Addition)

APPARATUS SERVICE REPAIR INSTRUCTIONS

KODAK INSTAMATIC 100, 300, 400 CAMERAS

Deformed Right Battery Contact (Part No. 163847)

It has been observed that #170203 Wedge - Right Battery Contact is not being installed correctly. The part name and the installation drawing obviously were not sufficiently descriptive.

The function of this part, #170203 Wedge, is to act as a stop for the battery. That is, it prevents battery from being depressed far enough to deform battery contact.

Wedge should be installed at the corner of the frame, similar to the boss that is molded in the frame of late models. It should not be installed under battery contact.

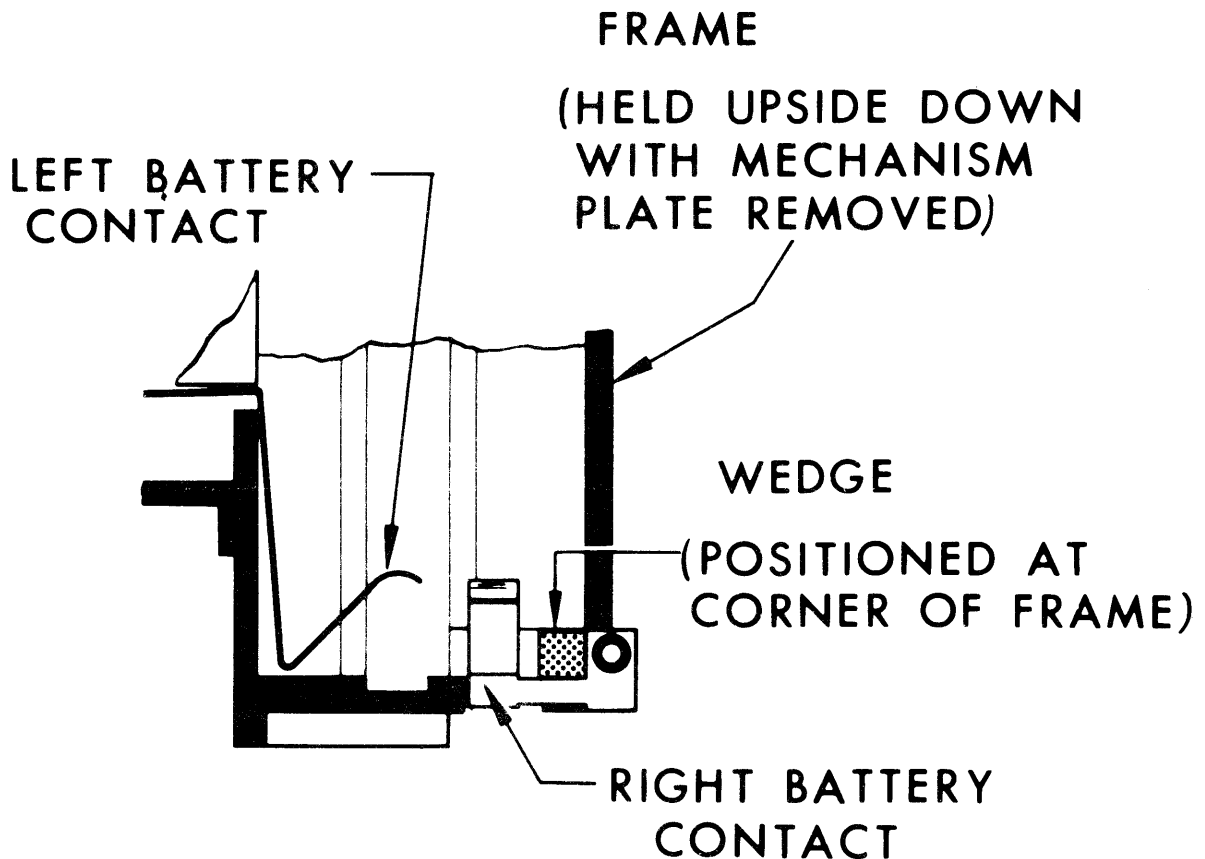

EASTMAN KODAK COMPANY

F. H. WAKELEY, MANAGER

APPARATUS SERVICE DEPARTMENT

SEPTEMBER 1963

NO. 1370

APPARATUS SERVICE REPAIR INSTRUCTIONS

KODAK INSTAMATIC 100, 300 and 400 CAMERAS

Deformed Right Battery Contact (Part No. 163847)

It has been observed that the right battery contact (Part No. 163847) has become deformed in some early models of the Kodak Instamatic 100, 300 and 400 Cameras. This deformation is caused by excessive compression of the contact, which then takes a set. The result is that electrical contact is lost between the battery and the contact or between the battery and the battery cover.

Cameras produced during and after the sixth period of this year have an additional boss on the frame in the battery compartment. This boss prevents inward movement of the battery which could deform the contact.

In order to prevent the battery from deforming the battery contact, a wedge is now available from Apparatus Parts Service as:

#170203 - Wedge - Right Battery Contact

An initial supply of these wedges will be sent to the Apparatus Service Department in each Sales Division; Warranty Service Shops should order from Apparatus Parts Service as required.

Effective immediately, this wedge should be installed in all Kodak Instamatic 100, 300 and 400 Cameras received which have a Camerosity code earlier than the sixth period of this year and which have no boss on frame to support battery, before return to the customer. The method for installing this wedge is described on the back of this bulletin. The Camerosity code is stamped on the bottom on the black plastic frame below square film aperture.

As a reminder, the Camerosity code is listed below. First two letters indicate period of manufacture and second two letters indicate year.

C A M E R O S I T Y
1 2 3 4 5 6 7 8 9 0

EASTMAN KODAK COMPANY

F. H. WAKELEY, MANAGER

APPARATUS SERVICE DEPARTMENT

INSTALLATION OF WEDGE (Part No. 170203)

1. Open battery cover and remove batteries. Reach into battery compartment with a suitable tool and form right battery contact toward battery cover. When contact is formed properly, approximately 1/4-inch from bottom of battery compartment, it will support a battery so that its base is flush with edge of mechanism plate and frame under vinyl wrapper.
2. Push a pointed tool into long side of wedge (Part No. 170203) with sufficient force to hold wedge during installation.
3. Apply styrene cement to lower side of wedge. Styrene cement may be purchased in most hobby shops (used for plastic kits) or small tubes of "Styro Weld", Part No. 761699, maybe ordered from Apparatus Parts Service, Rochester 4, New York.
4. Insert wedge in camera with long side laying flat on bottom of battery compartment and face of wedge against mechanism plate.
5. Hold wedge in position momentarily with tool. Leave camera in an inverted position until cement dries enough to hold wedge.

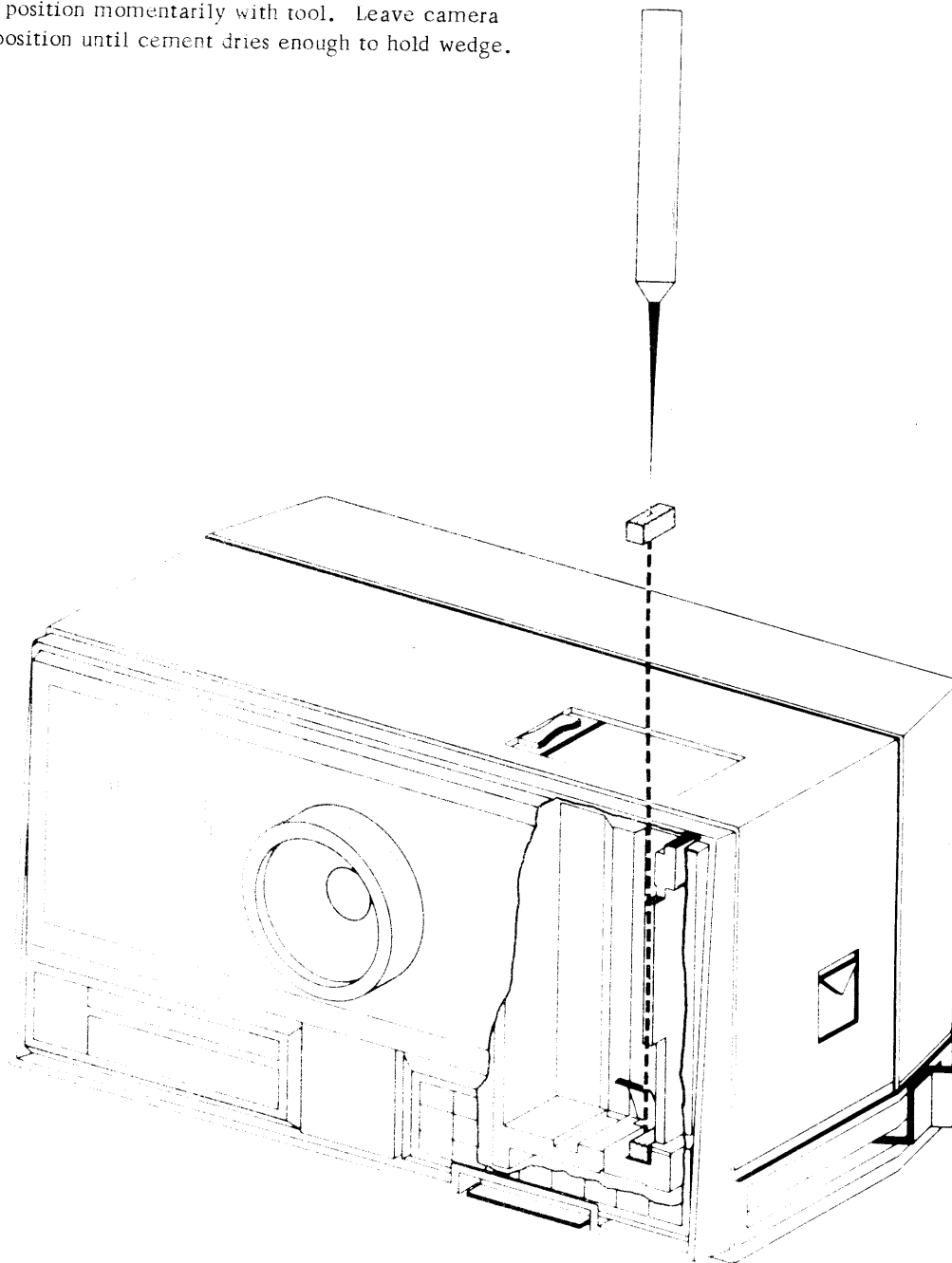

NOVEMBER 1964

NO. 1439

APPARATUS SERVICE REPAIR INSTRUCTIONS

INSTAMATIC 100, 150, 300 and 400 CAMERAS

Intermittent Flash Complaint

Occasionally, a Kodak Instamatic Camera owner may experience repeated, intermittent flash failure even though his camera proves to be satisfactory when subjected to all recommended tests. The purpose of this bulletin is to review the flash circuit and point out what may be the one logical explanation for his trouble.

The flash lamp in an Instamatic Camera is actually fired by opening a shorting circuit and allowing electrical current to flow in the firing circuit. In the schematic diagram below, switch "A" is closed when the shutter is cocked. As the shutter release is pressed downward switch "B" also closes, thus completing the shorting loop. As the shutter is tripped, switch "A" opens; current then flows through the lamp and fires it.

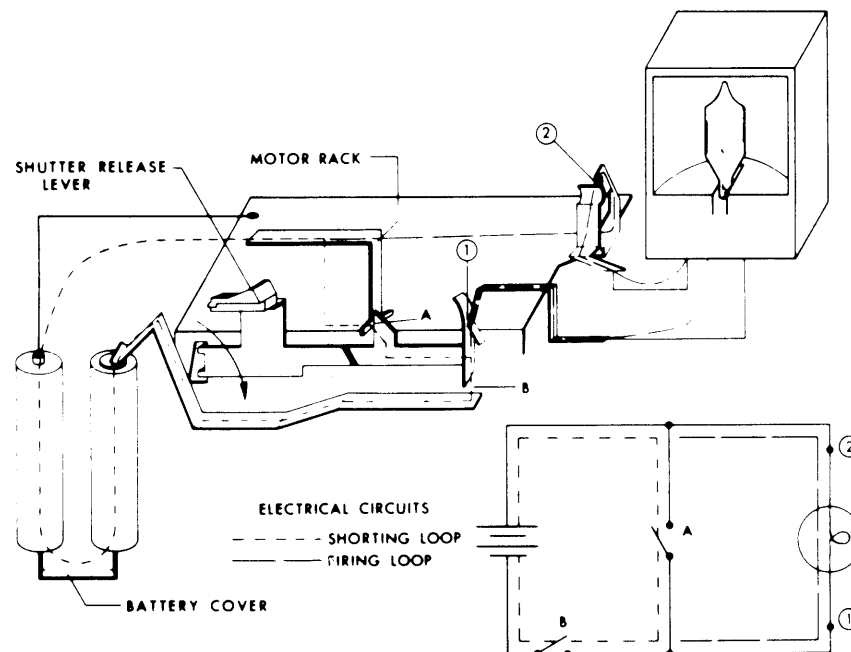

The instruction book furnished with each camera directs the user: . . . "Take the picture by *SLOWLY* pressing down the shutter release all the way". While these instructions constitute good picture-making practice, intermittent flash failure may result if it is carried to an extreme. Many times a user will hold the shutter release partially depressed awaiting the desired pose of a subject or to record a particular event at a decisive moment. Others depress the shutter release VERY slowly as a means of being certain there is no camera movement. In either case there is a considerable drain on the batteries through the shorting loop and flash failure may result. Since the batteries being marketed today recover relatively fast, normal cycling of the camera may result in the lamp being fired on the following exposure, providing the shutter is released in a normal manner. Occasionally, batteries may recover so rapidly that the lamp will flash after the shutter has tripped but before the release lever has been returned to the "up" position.

It is suggested that users be informed of this situation if, but only if, testing reveals there is no mechanical or electrical malfunction to explain intermittent flash failure. However, they should be cautioned against a tendency to over-correct by "*plunging*" the shutter release to the full extent of its travel, as poor pictures could result because of camera movement. Consequently, instructions should be explicit and indicate that the shutter release need not be pushed rapidly; it should be depressed slowly but not held in a partially depressed position.

EASTMAN KODAK COMPANY

F.H. WAKELEY, MANAGER

APPARATUS SERVICE DEPARTMENT

AUGUST 1963

NO. 768427

Servicing the

Kodak Instamatic 100 Camera



EASTMAN KODAK COMPANY
Apparatus Service Department
ROCHESTER 4, NEW YORK

TABLE OF CONTENTS

1. SHUTTER	5
1.1 SPECIFICATIONS-----	5
1.2 SERVICE HINTS-----	5
1.3 REMOVAL OF FRONT FROM CAMERA-----	6
1.4 REMOVAL OF TOP FROM CAMERA-----	7
1.5 REMOVAL OF FLASHHOLDER-----	7
1.6 REMOVAL OF SHUTTER SPEED LEVER-----	7
1.7 REMOVAL OF SHUTTER BLADE SPRING-----	7
1.8 REMOVAL OF SHUTTER DRIVE LEVER SPRING-----	7
2. FILM TRANSPORT	8
2.1 SPECIFICATIONS-----	8
2.2 SERVICE HINTS-----	8
2.3 REMOVAL OF MECHANISM PLATE FROM FRAME-----	9
2.4 DISASSEMBLY OF MECHANISM PLATE-----	9
2.5 REMOVAL OF METERING AND SENSING LEVERS-----	10
3. HOUSING	11
3.1 SPECIFICATIONS-----	11
3.2 SERVICE HINTS-----	11
3.3 DISASSEMBLY OF FRONT ASSEMBLY-----	12
3.4 DISASSEMBLY OF TOP ASSEMBLY-----	13
3.5 REMOVAL OF BACK ASSEMBLY-----	13
3.6 REMOVAL OF VIEWFINDER WINDOW-----	13
3.7 REMOVAL OF BATTERY CONTACTS-----	13
4. CEMENT AND LUBRICANT	14
4.1 CEMENT-----	14
4.2 LUBRICANT-----	14

SERVICE INSTRUCTIONS
KODAK INSTAMATIC 100 CAMERA

Service instructions for this camera are separated on a functional basis for clarity and ease of use by the serviceman. The instructions include specifications and service hints. The service hints sections have been written in a condition, cause, and remedy format for easy reference.

Service Tool #1065 - Kodak Demonstration Cartridge is useful in checking camera action during repair.

SEQUENCE OF OPERATION

Flashholder raised-----	Contacts ① and ② made
After an exposure but before film is advanced-----	A and B open
When film advance lever is moved-----	A closes
Shutter release lever starts down-----	B closes (current flows thru shorting loop)
Shutter release lever continues down and shutter is tripped----	A opens (current flows thru firing loop), bulb fires
Shutter release lever rises-----	B opens

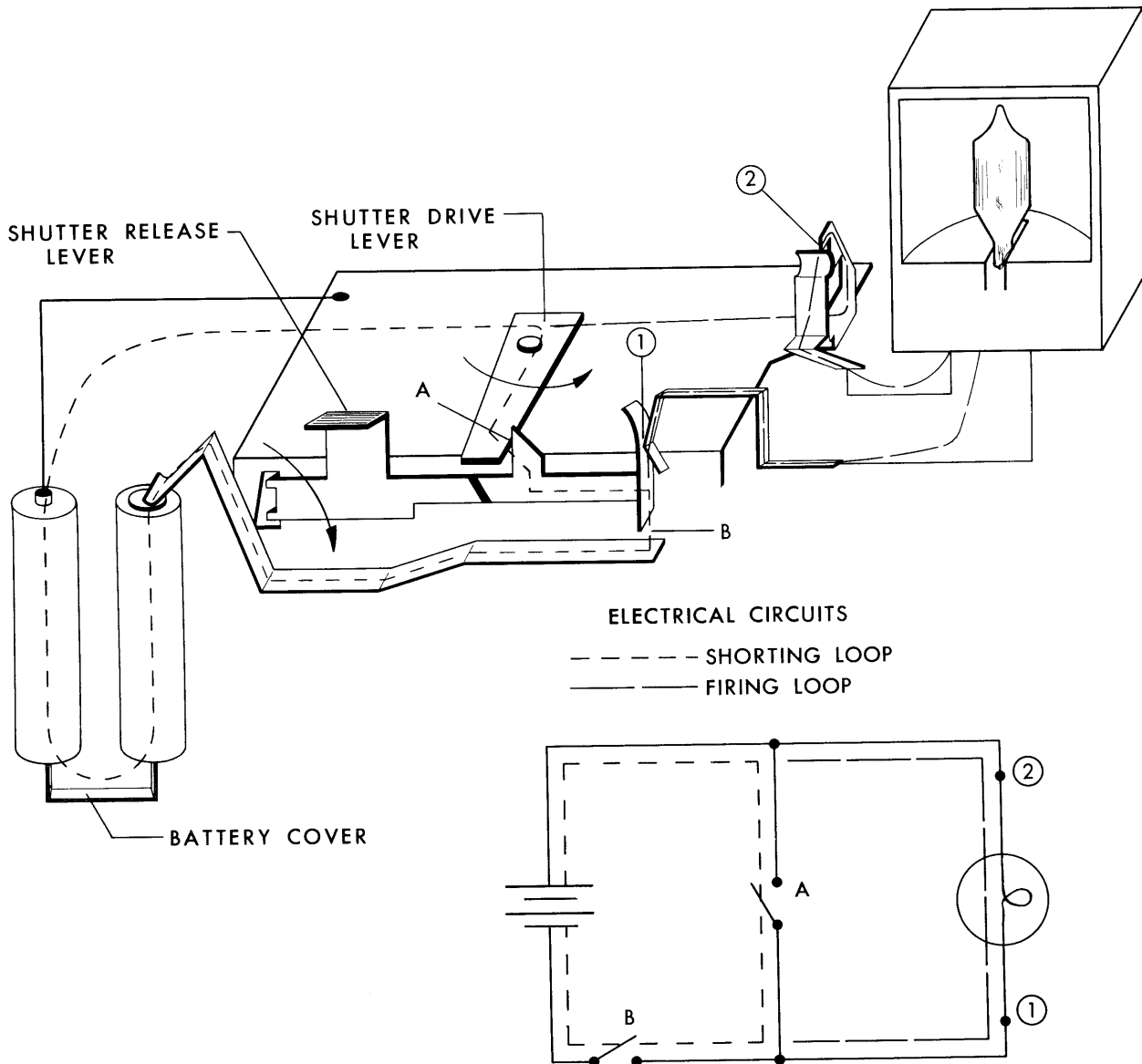

1. SHUTTER

1.1 SPECIFICATIONS

a) Shutter Speeds:

Daylight Speed, Flashholder down - Total Time: 10 to 16 milliseconds
Flash Speed, Flashholder up - Total Time: 19 to 28 milliseconds

- b) Flash synchronization may be checked with a flashbulb. When viewing from film plane, a full bright aperture opening must be observed when bulb is flashed. Shutter release should be pressed extremely slowly for this check. An alternate method of checking flash synchronization is by the following two observations (made with the front removed, instruction 1.3): (1) it must not be possible to close contact B (see page 4) until after the DEP mechanism is cleared, but (2) it must close before shutter is tripped.
- c) After shutter has been set by movement of advance lever and DEP has been cleared by sensing lever, camera should flash an AG1 test lamp (part no. 761743) when shutter release lever is depressed. It should not be possible to flash a lamp when shutter release lever is held in DEP position.
- d) Shutter release lever should: operate smoothly without excessive force; trip shutter and return to UP position when released.
- e) Flashholder contact should connect lamp socket to flash circuit when flashholder is raised and disconnect lamp socket from flash circuit when depressed. Flash contact must be maintained while flashholder is in raised position even when flashholder is "rocked" slightly.

1.2 SERVICE HINTS

a) Failure to flash.

Before investigating camera, batteries and flash bulb contacts should be checked.

The flash circuit of Kodak Instamatic Cameras is unique. The drawing on the opposite page pictorially and schematically shows this circuit.

Cause - loose battery cover.

Remedy - form bottom vinyl covering down to make battery contact fit tighter and/or install a new battery cover. The drawing shows the most effective position for forming the covering.

Cause - battery contact in camera deformed and battery rests too deeply in camera to make contact with battery cover.

Remedy - reach into battery compartment with a suitable tool and form battery contact toward battery cover. When batteries are positioned in battery compartment, they should be slightly above edge of mechanism plate and be depressed by battery cover when it is closed.

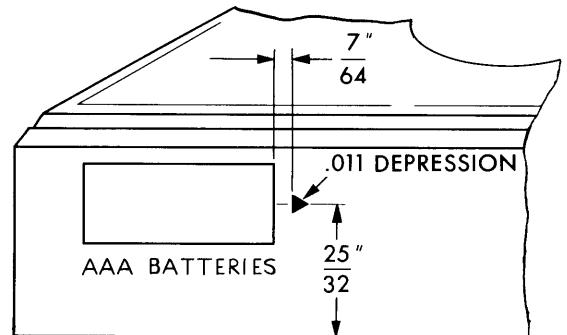

Cause - excessive lubrication on surface of frame which contacts back of flashholder. Small metal contact on back of flashholder picks-up this excessive lubrication and the lubrication prevents good flash contact.

Remedy - remove flashholder from frame and clean out lubrication on surface of frame which contacts back of flashholder.

1. SHUTTER

b) Shutter will not trip and film advance lever will not return.

Cause - shutter driver not "cocking".

Remedy - form end of film advance lever so that it will move shutter driver farther and to the "cocked" position.

c) Shutter held open.

Cause - shutter trapped by shutter speed lever.

Remedy - install new shutter speed lever or form upper arm of speed lever down toward bottom of camera so that shutter tang cannot pass arm of speed lever when flashholder is down. The shutter can be trapped accidentally by not raising flashholder fully. Camera should only be operated with flashholder all the way up or completely closed.

d) Shutter speed slow.

Cause - excessive lubricant on shutter blade.

Remedy - clean shutter blade and surface of mechanism plate.

e) Shutter speed does not decrease when flashholder is raised.

Cause - shutter speed lever does not change in position.

Remedy - install new speed lever or form speed lever so that it has sufficient spring action to move away from shutter.

f) Flash possible even when shutter release lever is held by double exposure prevention device.

Cause - flash circuit not completed or an electrical short in shorting circuit.

Remedy - tighten upper mechanism plate screw so that there is good contact between right battery contact and mechanism plate.

Left battery contact should not touch silver part of shutter release. If it does touch at any time, there will be an incorrect electrical short.

Brass portion of shutter release lever should not touch mechanism plate. This also will create an improper electrical short.

1.3 REMOVAL OF FRONT FROM CAMERA

a) Raise flashholder partially by depressing release bar.

b) Remove two flat head screws from sides and one longer flat head screw from bottom.

c) Open back of camera and remove sensing lever baffle. Baffle is most easily removed by placing a small tool into slot in baffle at sensing lever and then press downward and outward with tool to disengage top edge of baffle from frame. When replacing baffle, position lower edge of baffle to frame, then allow top edge of baffle to come down into contact with frame, slot in baffle over sensing lever. Press baffle down into frame.

d) Remove round head screw, immediately below aperture, from frame.

e) Pry vinyl covered side panel out over back latch plate.

f) Remove front from frame. Battery cover, which is trapped between vinyl bottom panel and frame will fall out. When replacing, position battery cover with printing at bottom of camera and visible thru hole in bottom panel. "Open" arrow should point toward center of camera.

g) Before replacing front to frame, form tab on top vinyl panel out slightly so that it may be engaged in slot in front next to viewfinder lens.

h) Position left end of front to frame with hand strap plate fitting into depression on frame. Rock front down and engage tab on top panel. Reposition battery cover if necessary and snap front to frame.

1. SHUTTER

1.4 REMOVAL OF TOP FROM CAMERA

- a) Raise flashholder partially by depressing release bar.
- b) Pry up and remove metal rear top cover plate. It is cemented in position.
- c) Remove two screws holding top to frame.
- d) Remove flat head screw from side panel immediately above back latch.
- e) Film advance lever must be in the back (normal) position. Remove top from camera.
- f) Before replacing top, form tab on top vinyl panel out slightly so that it may be engaged in slot in front next to viewfinder lens. Also check to make sure clear plastic viewfinder winding window is still in position in frame.

1.5 REMOVAL OF FLASHHOLDER

- a) Remove front from camera, instruction 1.3.
- b) Raise flashholder fully. Twist flashholder to disengage side closest to outside of camera and lift flashholder from frame.
- c) Replace flashholder by compressing flashholder contact against end of shutter release lever and rock flashholder into frame. Hold shutter speed lever toward shutter stud. Press flashholder in against frame and slide down. Be careful not to distort shutter spring when sliding flashholder down.

1.6 REMOVAL OF SHUTTER SPEED LEVER

- a) Remove front from camera, instruction 1.3, and raise flashholder fully.
- b) Shutter speed lever is trapped in position by mechanism plate. "Barbs" on lever contact depressions in frame.
- c) When replacing speed lever, simply slip "barb" end of speed lever between mechanism plate and frame. Locating tab at upper end of speed lever should be carefully positioned on shutter side of raised tab, which holds shutter spring on mechanism plate.

1.7 REMOVAL OF SHUTTER BLADE SPRING

- a) Remove front from camera, instruction 1.3.
- b) Disengage shutter blade spring from tab on shutter and tab on mechanism plate. Lift spring from shutter stud.
- c) When reassembling, position shutter spring to shutter stud with short leg closest to mechanism plate. Engage short leg of spring in notch on tab of shutter and long leg in notch on tab of mechanism plate. Shutter spring should not touch metering lever or shutter speed lever when correctly assembled.

1.8 REMOVAL OF SHUTTER DRIVE LEVER SPRING

- a) Remove top from camera, instruction 1.4.
- b) Disengage shutter drive lever spring from tab on mechanism plate and tab on shutter drive lever. Unwind loops of spring from stud.
- c) To install shutter drive lever spring, start with shortest leg down toward mechanism plate. Wind loops of spring onto stud. Engage short leg of spring with tab on shutter drive lever and wind up spring and engage long leg in notch on tab of mechanism plate.

2. FILM TRANSPORT

2.1 SPECIFICATIONS

- a) Film advance lever should operate smoothly and spring back fully when released.
- b) Film advance lever should cock shutter during first complete stroke of winding for each exposure.
- c) Film should advance as film advance lever is actuated and stop at each proper location for exposure (numbers on film backing paper, perforations on film in demonstration cartridge).
- d) Shutter release lever should be held by double exposure prevention device until film has been advanced fully to exposure location.

2.2 SERVICE HINTS

- a) Accidental jamming of film advance lever.

Cause - moving film sensing lever toward film advance lever either before or during actuation of film advance lever.

Remedy - press film sensing lever lightly toward front of camera, push film advance lever forward and allow it to return to rest position. Release film sensing lever and trip shutter.

This condition may also be rectified by simply placing a fresh film cartridge in camera and moving the film advance lever. The film backing paper in the cartridge will hold the film sensing lever in and allow actuation of film advance lever.

Cause - holding shutter release lever down, after shutter has been tripped, while moving film advance lever.

Remedy - if there is film in the camera, simply allow shutter release lever to rise and then actuate film advance lever.

If there is no film in camera, press film sensing lever lightly toward front of camera, push film advance lever forward and allow it to return to rest position. Release film sensing lever and trip shutter.

- b) Film transport system skipping exposures.

Cause - metering lever not engaging ratchet of clutch properly.

Remedy - examine operation of metering lever and condition of teeth on clutch ratchet. If metering lever action is bound, remove bind. If it is necessary to install a new metering lever, check the number of teeth on clutch ratchet, which must have 72 teeth, see instruction 2.5. If it does not, install a new clutch assembly.

If teeth on clutch ratchet are not full or show wear, install a new clutch assembly.

- c) Film advance lever binds and fails to return.

Cause - burr on edge of film advance lever rubbing on top of mechanism plate.

Remedy - position a knife blade through slot in camera body and between lower side of film advance lever and top of mechanism plate. Move sharp edge of blade toward front of camera, with force, to remove burr.

- d) Film Advance lever jams. (Other than accidental).

Cause - clutch assembly is defective.

Remedy - replace the clutch assembly.

Cause - shutter driver not "cocking".

Remedy - form end of film advance lever so that it will move shutter driver further and to the "cocked" position.

2. FILM TRANSPORT

2.3 REMOVAL OF MECHANISM PLATE FROM FRAME

- a) Remove top from camera, instruction 1.4.
- b) Remove front and flashholder from camera, instruction 1.3 and 1.5.
- c) Actuate film advance lever one full stroke to cock shutter and allow lever to return to the rest position under spring tension. Do not "sense" mechanism by moving sensing lever. Metering and sensing levers are now in correct position so that mechanism plate can be removed without disturbing them.
- d) Remove winding lever spring by lifting spring loop from post on frame and disengaging opposite end from film advance lever.
- e) Disengage locating tab of shutter speed lever from contact with raised tab on mechanism plate.
- f) Remove two screws holding mechanism plate to frame.
- g) Pry up lower front edge of mechanism so that it snaps out off bosses on frame.
- h) Raise mechanism plate from frame. Care should be taken so that mechanism plate is not distorted. Platforms for shutter driver and winding mechanism must remain perpendicular to front surface of mechanism plate.
- i) When reassembling mechanism plate, first position sensing and metering levers correctly by moving sensing lever to the left so that it holds metering lever as far forward as possible. Cock shutter drive lever and return film advance lever to normal rest position. Guide mechanism plate down onto frame with cut-out in mechanism plate going around tab on metering lever: move metering lever tab slightly if necessary. Push mechanism plate down and snap over posts on frame. Late style frames have a boss on top surface near slot for safety pawl spring. If mechanism plate does not have a hole to accept boss, a hole must be drilled in mechanism plate. Be sure small right battery contact is located properly under mechanism plate. Attach mechanism plate to frame with two screws. Assemble film advance lever spring and check operation.

2.4 DISASSEMBLY OF MECHANISM PLATE

- a) Press in on tab of back latch and allow it to snap down into the "closed" position.
- b) Compress clutch drive spring fingers on underside of clutch assembly and slip black plastic spool driver from between clutch and back latch.
- c) Move film advance lever to forward position. Raise end of film advance lever and slip clutch assembly from mechanism plate. When replacing clutch assembly, flat washer in assembly fits into recess of ratchet wheel and mechanism plate slips between washer and upper gear.
- d) Remove shutter spring: short leg hooks on shutter and long leg contacts tab on mechanism plate.
- e) Disconnect shutter drive lever spring and wind it off stud. When replacing spring, position with short leg down toward mechanism plate, wind loops onto stud, engage short leg with tab on drive lever and long leg with tab on mechanism plate.
- f) Pull brass safety pawl spring from mechanism plate. Spring should have sufficient tension when assembled to move pawl into ratchet when pawl action is not restricted by shutter driver or film advance lever.
- g) Remove back latch spring. Snap back latch from mechanism plate by sliding it up and disengaging small tab of latch which contacts mechanism plate at front corner. If it is necessary to raise folded-over section of latch, a new one must be installed; if original is re-folded, it will break. New latches will have the fold-over section perpendicular to remainder of latch so that after positioning, it can be folded-over against mechanism plate with finger pressure. Do not use pliers; section will spring back to give proper clearance.
- h) Disengage shutter release lever spring from tab on mechanism plate. Rotate spring and disengage from shutter release lever.
- i) Remove shutter release lever from mechanism plate.

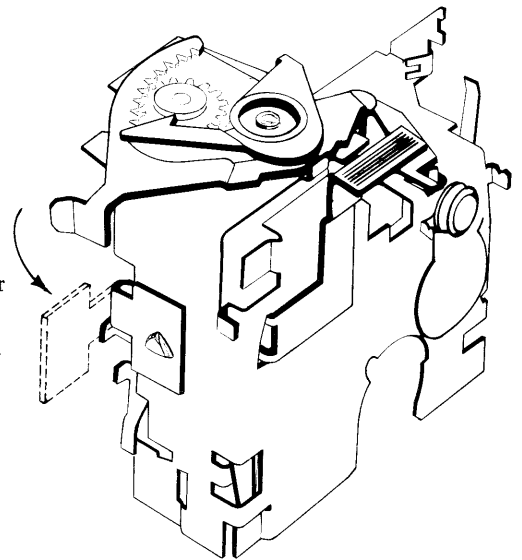

2. FILM TRANSPORT

2.5 REMOVAL OF METERING AND SENSING LEVERS

- a) Remove front and top from camera, instructions 1.3 and 1.4.
- b) Remove mechanism plate, instruction 2.3.
- c) Disconnect and lift off metering lever spring. Short leg of spring fits into "well" in frame, long leg contacts metering lever.
- d) Lift off brass spacer and metering lever. If a new metering lever is installed, it is necessary to check clutch assembly in mechanism plate. Clutch assembly must have a lower ratchet with 72 teeth, but many early cameras have clutches with 90-tooth ratchets. These must be removed and a new clutch (72-tooth ratchet) fitted when a new metering lever is installed.
- e) Disconnect and lift out sensing lever spring. Short formed end of spring fits into hole in frame and long end contacts sensing lever.

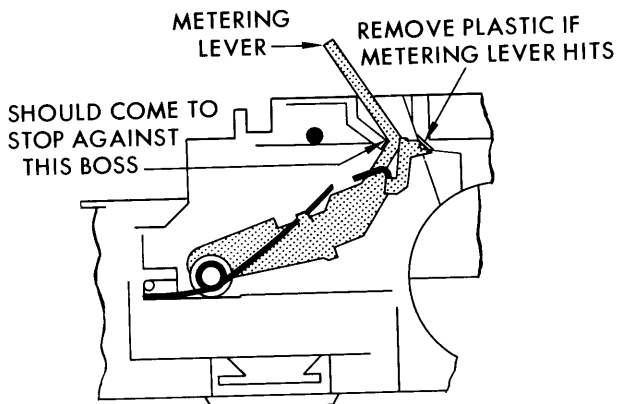
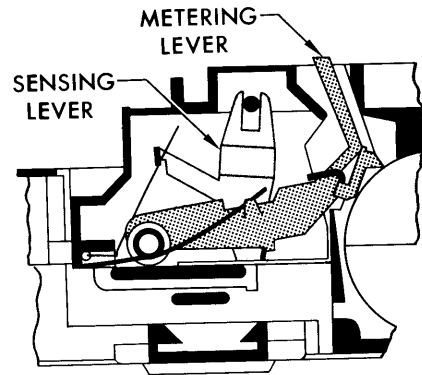

- f) Lift "yoke" end of sensing lever from post on frame, disengage opposite end from slot in frame and lift out sensing lever.
- g) Lubricate sensing lever and metering lever, at contact points between levers and between levers and frame, with a very light grease such as A&O #61-3663 when re-assembling.
- h) When reassembling, check action of metering lever. Lower arm of lever should come to a stop against boss on frame. Pawl end of lever should not touch black plastic frame; see drawing.

3. HOUSING

3.1 SPECIFICATIONS

- a) Flashholder must pop-up at least slightly when release bar on front of camera is pressed.
- b) Raising flashholder to flash position should be possible without undue force after flashholder has been unlatched by release bar.
- c) Flashholder lamp socket should accept an AG1 flash bulb or test lamp without excessive force and retain it, if lamp has been inserted fully into flashholder.
- d) Lamp should be released when ejector lever is moved to its maximum travel. Lever should spring back when released.
- e) Back should fit case without severe interference.
- f) Back latch should snap down and hold back when it is closed.
- g) With a film cartridge in camera, back should pop-open slightly when back latch is moved up toward top of camera.
- h) Flashholder should latch securely when pressed down into camera.
- i) Taking lens should be securely held in position in front assembly.
- j) Battery cover should slide without severe interference but should be held securely in "closed" position by detent action. It should not be possible to even partially open battery cover accidentally by lightly moving finger over battery cover.

3.2 SERVICE HINTS

- a) Nameplate loose.

Cause - nameplate cemented to flashholder release bar, and actuation of bar loosens nameplate.

Remedy - remove satin finished "KODAK" nameplate, which is cemented into recess of shiny plate. Cement may be softened by placing a few drops of solvent such as methyl ethyl ketone just inside recess of shiny plate. Pry up satin plate by starting at upper corner just under "100".

Form flat part of release bar latch up away from front and remove cement from its surface. Form bar end of latch so that it will enter front perpendicularly. Raise flashholder. Press down upper-most section of latch so that flat section fits down into well of front, then lubricate the surface of this section. The lowering and lubricating of the flat area of latch prevents new nameplate from sticking to it.

To cement a new nameplate in position, "activate" the cement (which is pre-coated on back of nameplate) with some of the solvent used to loosen the plate. Chloroethene is an acceptable substitute solvent.

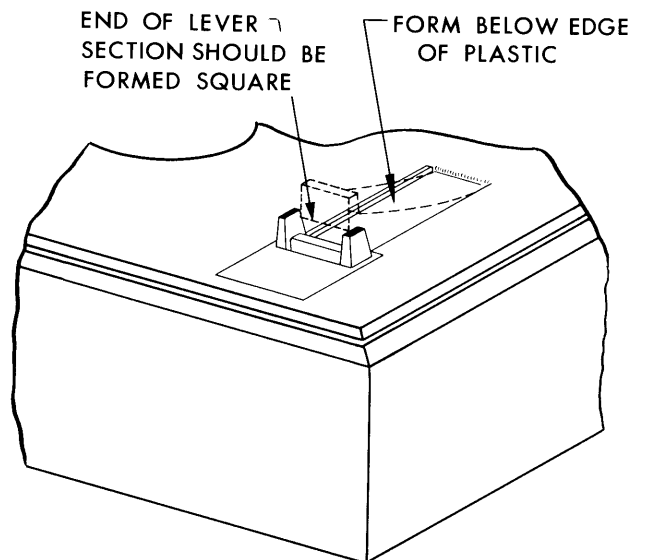

3. HOUSING

b) Flashholder will not "pop-up" at least 1/4-inch.

Cause - bind between front and flashholder or flashholder and frame.

Remedy - perform the following steps in order and actuate flashholder after each step and observe action.

With a pair of pliers, grasp plate to which hand strap is attached and pull outward.

Loosen side screw near hand strap plate, hold flashholder forward toward front with force, and tighten side screw again.

Position a knife blade immediately below flashholder release bar and form end of tang of release bar up toward top of camera.

With knife blade in same position, press in to compress tension of spring on front of flashholder.

Trim front edges of flashholder to remove sharp edge and any burrs. If flashholder is disassembled from camera, trim front edges for entire length of flashholder.

3.3 DISASSEMBLY OF FRONT ASSEMBLY

- a) Remove "KODAK" nameplate, instruction 3.2 a. Do not try to remove shiny plate; it is crimped to front assembly.
- b) Remove black bezels from front. These bezels are also cemented in position and are best removed by prying up at sides nearest viewfinder lens. They have a cement backing, but rather than activating this cement it is better to use a good rubber base cement such as A&O #10-1168 (Minnesota Mining and Manufacturing EC-1357).
- c) Lift out front viewfinder lens. When replaced, frosted section should go down toward taking lens. The supporting edges of viewfinder vary; some have short edge on right and others have it on the left, but either is acceptable.
- d) In order to remove taking lens or hand strap plate, front must be removed from camera, instruction 1.3.
- e) With front removed from camera and nameplate removed from front, instruction 3.3 a, lift out hand strap plate.

3. HOUSING

- f) If it is necessary to install a new taking lens, particular attention should be taken to observe lenses originally assembled to camera. Three different combinations have been used. If a new taking lens is installed, assemble only the new lens. Remove and discard all other parts, including retainer and lens (plano glass) in frame, and retainer and spacer in front. Retainer and lens in frame are most easily removed by applying heat (soldering iron) to retainer and pushing lens from front side. Position new lens directly to front, concave side toward film plane, and cement in place with a good styrene cement (same as that used in children's plastic model kits) or use HE 100 B which is available from Apparatus Parts Service. Be sure no cement or plastic burrs rise higher than edge of lens mount inside. These could interfere with shutter action.

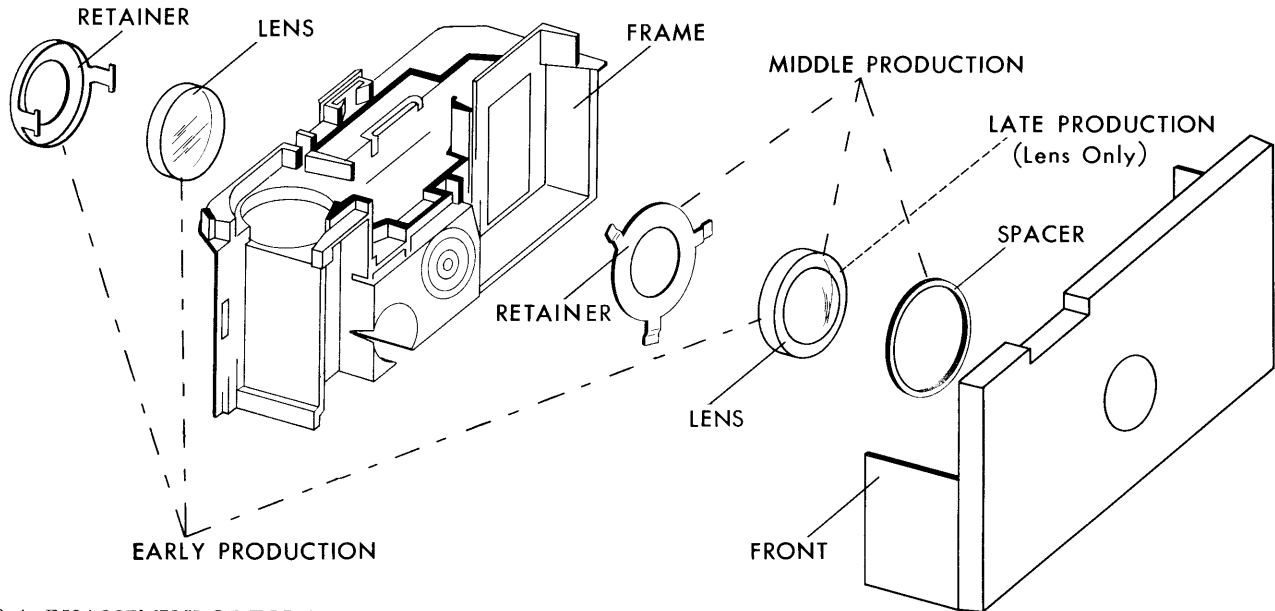

3.4 DISASSEMBLY OF TOP ASSEMBLY

- Remove black vinyl covering. It is cemented in position.
- Snap viewfinder baffle from top. Rear section of baffle slips into slot in top when reassembling.
- Pull viewfinder rear lens from top housing. It should be reassembled with beveled corner toward top of camera and nearest flashholder opening.

3.5 REMOVAL OF BACK ASSEMBLY

- Open camera back.
- Remove two screws holding back hinge plate to frame, then lift back and hinge from frame.
- Spread hinge arms of back assembly and snap out hinge plate.

3.6 REMOVAL OF VIEWFINDER WINDOW

- Remove top from camera, instruction 1.4.
- Lift viewfinder window from frame.

3.7 REMOVAL OF BATTERY CONTACTS

- Remove front and top from camera, instructions 1.3 and 1.4.
- Remove mechanism plate, instruction 2.3.
- Snap small right battery contact from frame. When reassembled, hole in contact must be located over hole in frame.
- Remove longer left battery contact by squeezing "barbed" sides together and pull from frame. When reassembled, left end of contact, which is closest to flashholder, must be parallel to edge of frame just above it.

4. CEMENT AND LUBRICANT

4.1 CEMENT - A&O #10-1168 or Minnesota Mining and Manufacturing (3M) #EC-1357 (Thinner-Toluol or Solvesso)

Left and right finder bezels to front assembly.

Black front top covering to top assembly.

Rear top cover plate to top assembly.

Front nameplate may also be attached with this cement, or cement backing on plate may be activated with methyl ethyl ketone or Chlorothene.

4.2 LUBRICANT - A&O #61-3663 or Dow Corning #33 Grease

Brush this lubricant at points of contact between the following parts:

Flashholder box and flashholder detent spring with front assembly.

Flashholder box and main camera frame but not any place which flash contacts touch.

Film advance lever teeth and clutch ratchet.

Film advance lever and top of mechanism plate.

Slot in mechanism plate which accepts clutch.

Mechanism plate and pivot point of shutter release lever.

Back latch and mechanism plate.

Pawl on metering lever which enters ratchet of clutch.

Metering lever tab and shutter release lever.

Metering lever tab and sensing lever tab.

Kodak

Part No. 768427
8-63